



Cladding Power Stripper (CPS Series)

Rev 11D

Description

The Cladding Power Stripper (CPS) is designed for efficiently stripping off residual cladding power, ASE and escaped core modes of double cladding fiber while preserving minimal degradation to signal power and beam quality.

Key Features

- High Power Handling
- Low Insertion Loss

Applications

- Fiber Laser

Specifications

Parameter	Unit	Value
Operating Wavelength Range ¹	nm	800 - 2000
Min. Stripping Efficiency ²	%	98
Max. Signal Insertion Loss	dB	0.3
Fiber Type for Input and Output	-	10/125 DCF or 20/130 DCF or 30/250 DCF
Max. Stripped Power	W	0 - 20 21 - 50 51 - 200 201 - 800
Package Type	mm	P2 P5 P9 P8
Operating Temperature	°C	- 5 to + 60
Storage Temperature	°C	- 40 to + 85

¹Represents the wavelength of the main light in the cladding which is requested to be stripped by the device.

²Fully filled condition.

Package Dimensions

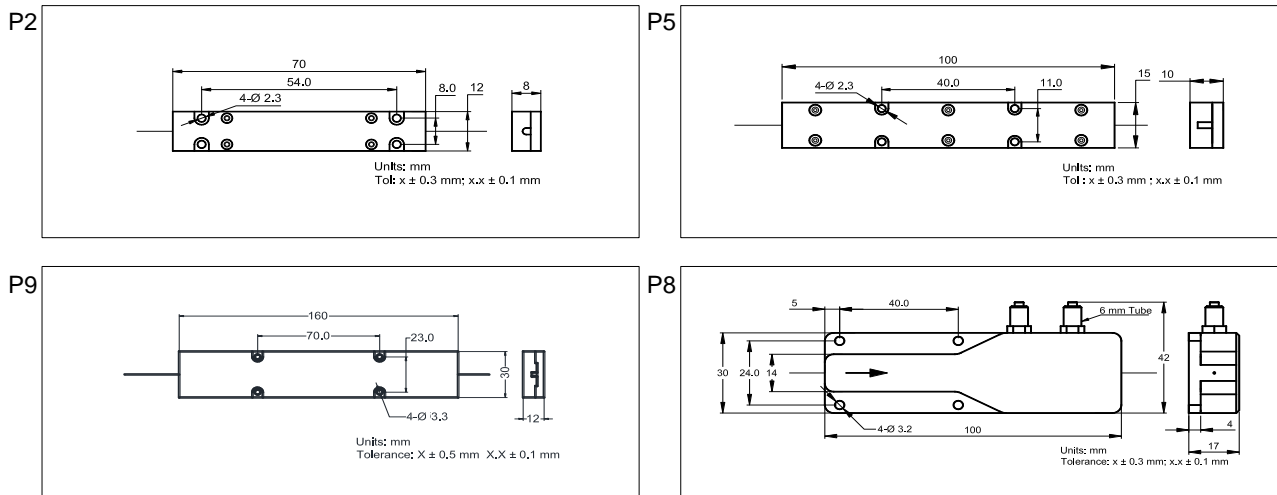

Ordering Information

CPS-①①①-②②②②-③③-④④④④-⑤-⑥

①①①: Operating Wavelength

915 - 915 nm

975 - 975 nm

SSS - Specify

②②②②: Signal Wavelength

1064 - 1064 nm

1550 - 1550 nm

SSSS - Specify

③③: Fiber Type

10 - LMA-GDF-10/125-M

20 - LMA-GDF-20/130-M

30 - LMA-GDF-30/250-M

SS - Specify

④④④: Stripped Power

020 - 0 to 20 W
050 - 21 to 50 W
200 - 51 to 200 W
800 - 201 to 800 W

⑤: Package Type

2 - P2: 70 (L) × 12 (W) × 8 (H)
5 - P5: 100 (L) × 15 (W) × 10 (H)
9 - P9: 160 (L) × 30 (W) × 12 (H)
8 - P8: 100 (L) × 30 (W) × 17 (H) (Water Cooling)

⑥: Fiber Length

Q - 0.75 m
S - Specify